

National Testing Agency

Question Paper Name : B Tech 27 Aug 2021 Shift 2
Subject Name : B TECH
Creation Date : 2021-08-27 22:20:30
Duration : 180
Total Marks : 300
Display Marks: Yes

B TECH

Group Number : 1
Group Id : 864351251
Group Maximum Duration : 0
Group Minimum Duration : 180
Show Attended Group? : No
Edit Attended Group? : No
Break time : 0
Group Marks : 300
Is this Group for Examiner? : No

Physics Section A

Section Id : 864351944
Section Number : 1
Section type : Online
Mandatory or Optional : Mandatory
Number of Questions : 20
Number of Questions to be attempted : 20
Section Marks : 80

Enable Mark as Answered Mark for Review and Clear Response : Yes
Sub-Section Number : 1
Sub-Section Id : 8643511171
Question Shuffling Allowed : Yes

Question Number : 1 Question Id : 86435120620 Question Type : MCQ Option Shuffling : Yes Is Question Mandatory : No
Correct Marks : 4 Wrong Marks : 1

Water drops are falling from a nozzle of a shower onto the floor, from a height of 9.8 m. The drops fall at a regular interval of time. When the first drop strikes the floor, at that instant, the third drop begins to fall. Locate the position of second drop from the floor when the first drop strikes the floor.

Options :

86435168441. 2.45 m

86435168442. 7.35 m

86435168443. 2.94 m

86435168444. 4.18 m

Question Number : 2 Question Id : 86435120621 Question Type : MCQ Option Shuffling : Yes Is Question Mandatory : No
Correct Marks : 4 Wrong Marks : 1

Match List - I with List - II.

List - I

- (a) R_H (Rydberg constant)
- (b) h (Planck's constant)
- (c) μ_B (Magnetic field energy density)
- (d) η (coefficient of viscosity)

List - II

- (i) $\text{kg m}^{-1}\text{s}^{-1}$
- (ii) $\text{kg m}^2\text{s}^{-1}$
- (iii) m^{-1}
- (iv) $\text{kg m}^{-1}\text{s}^{-2}$

Choose the **most appropriate** answer from the options given below :

Options :

86435168445. (a)-(ii), (b)-(iii), (c)-(iv), (d)-(i)

86435168446. (a)-(iii), (b)-(ii), (c)-(i), (d)-(iv)

86435168447. (a)-(iv), (b)-(ii), (c)-(i), (d)-(iii)

86435168448. (a)-(iii), (b)-(ii), (c)-(iv), (d)-(i)

Question Number : 3 Question Id : 86435120622 Question Type : MCQ Option Shuffling : Yes Is Question Mandatory : No

Correct Marks : 4 Wrong Marks : 1

Two discs have moments of inertia I_1 and I_2 about their respective axes perpendicular to the plane and passing through the centre. They are rotating with angular speeds, ω_1 and ω_2 respectively and are brought into contact face to face with their axes of rotation coaxial. The loss in kinetic energy of the system in the process is given by :

Options :

86435168449.
$$\frac{I_1 I_2}{2(I_1 + I_2)} (\omega_1 - \omega_2)^2$$

86435168450.
$$\frac{I_1 I_2}{(I_1 + I_2)} (\omega_1 - \omega_2)^2$$

86435168451.
$$\frac{(\omega_1 - \omega_2)^2}{2(I_1 + I_2)}$$

86435168452.
$$\frac{(I_1 - I_2) \omega_1 \omega_2}{2(I_1 + I_2)}$$

Question Number : 4 Question Id : 86435120623 Question Type : MCQ Option Shuffling : Yes Is Question Mandatory : No Correct Marks : 4 Wrong Marks : 1

A player kicks a football with an initial speed of 25 ms^{-1} at an angle of 45° from the ground. What are the maximum height and the time taken by the football to reach at the highest point during motion ? (Take $g = 10 \text{ ms}^{-2}$)

Options :

86435168453.
$$h_{\max} = 10 \text{ m} \quad T = 2.5 \text{ s}$$

86435168454.
$$h_{\max} = 15.625 \text{ m} \quad T = 3.54 \text{ s}$$

86435168455. $h_{\max} = 15.625 \text{ m}$ $T = 1.77 \text{ s}$

86435168456. $h_{\max} = 3.54 \text{ m}$ $T = 0.125 \text{ s}$

Question Number : 5 Question Id : 86435120624 Question Type : MCQ Option Shuffling : Yes Is Question Mandatory : No Correct Marks : 4 Wrong Marks : 1

The boxes of masses 2 kg and 8 kg are connected by a massless string passing over smooth pulleys. Calculate the time taken by box of mass 8 kg to strike the ground starting from rest. (use $g = 10 \text{ m/s}^2$) :

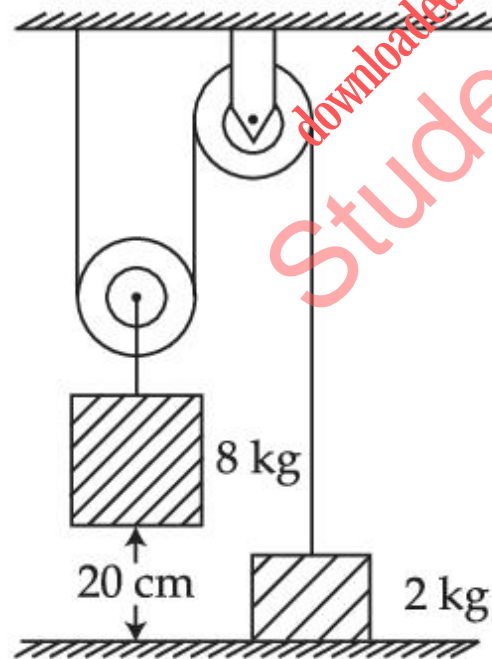

Options :

86435168457. 0.2 s

86435168458. 0.34 s

86435168459. 0.25 s

86435168460. 0.4 s

Question Number : 6 Question Id : 86435120625 Question Type : MCQ Option Shuffling : Yes Is Question Mandatory : No Correct Marks : 4 Wrong Marks : 1

A mass of 50 kg is placed at the centre of a uniform spherical shell of mass 100 kg and radius 50 m. If the gravitational potential at a point, 25 m from the centre is V kg/m. The value of V is :

Options :

86435168461. -60 G

86435168462. -20 G

86435168463. -4 G

86435168464. +2 G

Question Number : 7 Question Id : 86435120626 Question Type : MCQ Option Shuffling : Yes Is Question Mandatory : No Correct Marks : 4 Wrong Marks : 1

The height of victoria falls is 63 m. What is the difference in temperature of water at the top and at the bottom of fall ?

[Given $1 \text{ cal} = 4.2 \text{ J}$ and specific heat of water $= 1 \text{ cal g}^{-1} \text{ }^\circ\text{C}^{-1}$]

Options :

86435168465. 0.014°C

86435168466. 0.147°C

86435168467. 1.476°C

86435168468. 14.76°C

Question Number : 8 Question Id : 86435120627 Question Type : MCQ Option Shuffling : Yes Is Question Mandatory : No Correct Marks : 4 Wrong Marks : 1

If the rms speed of oxygen molecules at 0°C is 160 m/s , find the rms speed of hydrogen molecules at 0°C .

Options :

86435168469. 332 m/s

86435168470. 80 m/s

86435168471. 640 m/s

86435168472. 40 m/s

Question Number : 9 Question Id : 86435120628 Question Type : MCQ Option Shuffling : Yes Is Question Mandatory : No Correct Marks : 4 Wrong Marks : 1

Three capacitors $C_1 = 2 \mu\text{F}$, $C_2 = 6 \mu\text{F}$ and $C_3 = 12 \mu\text{F}$ are connected as shown in figure. Find the ratio of the charges on capacitors C_1 , C_2 and C_3 respectively :

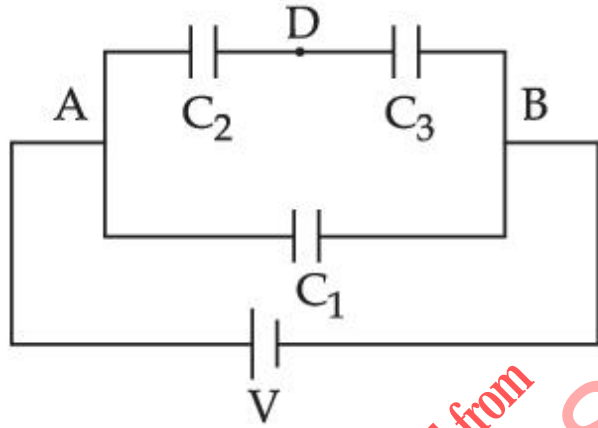

Options :

86435168473. 3 : 4 : 4

86435168474. 2 : 3 : 3

86435168475. 2 : 1 : 1

86435168476. 1 : 2 : 2

Question Number : 10 Question Id : 86435120629 Question Type : MCQ Option Shuffling : Yes Is Question Mandatory : No
Correct Marks : 4 Wrong Marks : 1

Figure shows a rod AB, which is bent in a 120° circular arc of radius R. A charge $(-Q)$ is uniformly distributed over rod AB. What is the electric field \vec{E} at the centre of curvature O?

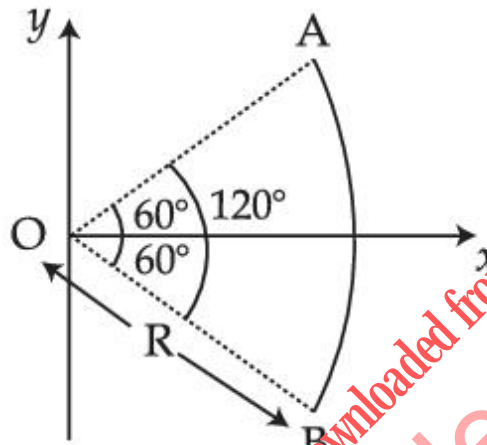

Options :

$$\frac{3\sqrt{3} Q}{8 \pi^2 \epsilon_0 R^2} (\hat{i})$$

86435168477.

$$\frac{3\sqrt{3} Q}{8 \pi^2 \epsilon_0 R^2} (-\hat{i})$$

86435168478.

$$\frac{3\sqrt{3} Q}{8 \pi \epsilon_0 R^2} (\hat{i})$$

86435168479.

86435168480. $\frac{3\sqrt{3} Q}{16 \pi^2 \epsilon_0 R^2} (\hat{i})$

Question Number : 11 Question Id : 86435120630 Question Type : MCQ Option Shuffling : Yes Is Question Mandatory : No
 Correct Marks : 4 Wrong Marks : 1

A coaxial cable consists of an inner wire of radius 'a' surrounded by an outer shell of inner and outer radii 'b' and 'c' respectively. The inner wire carries an electric current i_0 , which is distributed uniformly across cross-sectional area. The outer shell carries an equal current in opposite direction and distributed uniformly. What will be the ratio of the magnetic field at a distance x from the axis when (i) $x < a$ and (ii) $a < x < b$?

Options :

86435168481. $\frac{x^2}{a^2}$

86435168482. $\frac{a^2}{x^2}$

86435168483. $\frac{x^2}{b^2 - a^2}$

86435168484. $\frac{b^2 - a^2}{x^2}$

Question Number : 12 Question Id : 86435120631 Question Type : MCQ Option Shuffling : Yes Is Question Mandatory : No
Correct Marks : 4 Wrong Marks : 1

The colour coding on a carbon resistor is shown in the given figure. The resistance value of the given resistor is :

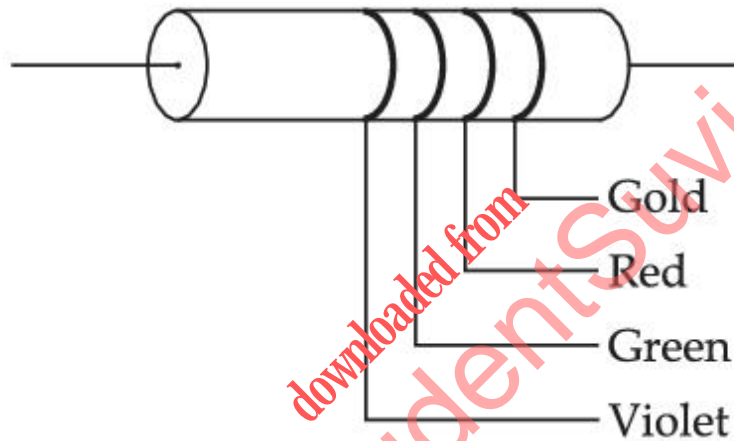

Options :

86435168485. $(5700 \pm 375) \Omega$
86435168486. $(7500 \pm 750) \Omega$
86435168487. $(5700 \pm 285) \Omega$
86435168488. $(7500 \pm 375) \Omega$

Question Number : 13 Question Id : 86435120632 Question Type : MCQ Option Shuffling : Yes Is Question Mandatory : No
Correct Marks : 4 Wrong Marks : 1

For full scale deflection of total 50 divisions, 50 mV voltage is required in galvanometer. The resistance of galvanometer if its current sensitivity is 2 div/mA will be :

Options :

86435168489. 1 Ω

86435168490. 2 Ω

86435168491. 4 Ω

86435168492. 5 Ω

Question Number : 14 Question Id : 86435120633 Question Type : MCQ Option Shuffling : Yes Is Question Mandatory : No

Correct Marks : 4 Wrong Marks : 1

Curved surfaces of a plano-convex lens of refractive index μ_1 and a plano-concave lens of refractive index μ_2 have equal radius of curvature as shown in figure. Find the ratio of radius of curvature to the focal length of the combined lenses.

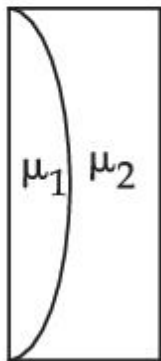

Options :

86435168493. $\mu_1 - \mu_2$

$$\frac{1}{\mu_1 - \mu_2}$$

86435168494.

$$\mu_2 - \mu_1$$

86435168495.

$$\frac{1}{\mu_2 - \mu_1}$$

86435168496.

Question Number : 15 Question Id : 86435120634 Question Type : MCQ Option Shuffling : Yes Is Question Mandatory : No

Correct Marks : 4 Wrong Marks : 1

If force (F), length (L) and time (T) are taken as the fundamental quantities. Then what will be the dimension of density :

Options :

$$[FL^{-3}T^3]$$

86435168497.

$$[FL^{-5}T^2]$$

86435168498.

$$[FL^{-4}T^2]$$

86435168499.

$$[FL^{-3}T^2]$$

86435168500.

Question Number : 16 Question Id : 86435120635 Question Type : MCQ Option Shuffling : Yes Is Question Mandatory : No

Correct Marks : 4 Wrong Marks : 1

A constant magnetic field of 1 T is applied in the $x > 0$ region. A metallic circular ring of radius 1 m is moving with a constant velocity of 1 m/s along the x -axis. At $t=0$ s, the centre O of the ring is at $x = -1$ m. What will be the value of the induced emf in the ring at $t=1$ s? (Assume the velocity of the ring does not change.)

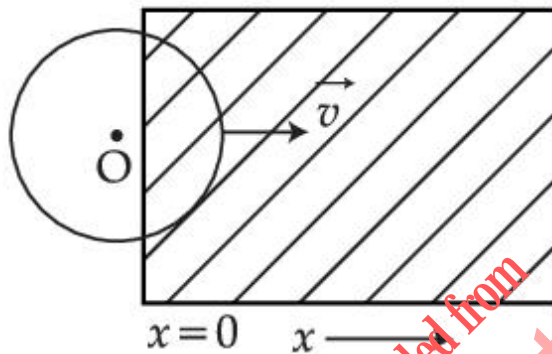

Options :

86435168501. 0 V
86435168502. 1 V
86435168503. 2 V
86435168504. 2π V

Question Number : 17 Question Id : 86435120636 Question Type : MCQ Option Shuffling : Yes Is Question Mandatory : No

Correct Marks : 4 Wrong Marks : 1

For a transistor α and β are given as $\alpha = \frac{I_C}{I_E}$ and $\beta = \frac{I_C}{I_B}$. Then the correct relation between α and β will be :

Options :

86435168505. $\alpha = \frac{\beta}{1 - \beta}$

86435168506. $\alpha\beta = 1$

86435168507. $\beta = \frac{\alpha}{1 - \alpha}$

86435168508. $\alpha = \frac{1 - \beta}{\beta}$

Question Number : 18 Question Id : 86435120637 Question Type : MCQ Option Shuffling : Yes Is Question Mandatory : No
Correct Marks : 4 Wrong Marks : 1

The light waves from two coherent sources have same intensity $I_1 = I_2 = I_0$. In interference pattern the intensity of light at minima is zero. What will be the intensity of light at maxima ?

Options :

86435168509. $2 I_0$

86435168510. $5 I_0$

86435168511. $4 I_0$

86435168512. I_0

Question Number : 19 Question Id : 86435120638 Question Type : MCQ Option Shuffling : Yes Is Question Mandatory : No Correct Marks : 4 Wrong Marks : 1

A monochromatic neon lamp with wavelength of 670.5 nm illuminates a photo-sensitive material which has a stopping voltage of 0.48 V. What will be the stopping voltage if the source light is changed with another source of wavelength of 474.6 nm ?

Options :

86435168513. 0.96 V

86435168514. 1.5 V

86435168515. 1.25 V

86435168516. 0.24 V

Question Number : 20 Question Id : 86435120639 Question Type : MCQ Option Shuffling : Yes Is Question Mandatory : No Correct Marks : 4 Wrong Marks : 1

An antenna is mounted on a 400 m tall building. What will be the wavelength of signal that can be radiated effectively by the transmission tower upto a range of 44 km ?

Options :

86435168517. 37.8 m

86435168518. 75.6 m

86435168519. 302 m

86435168520. 605 m

Physics Section B

Section Id :	864351945
Section Number :	2
Section type :	Online
Mandatory or Optional :	Mandatory
Number of Questions :	10
Number of Questions to be attempted :	5
Section Marks :	20
Enable Mark as Answered Mark for Review and Clear Response :	Yes
Sub-Section Number :	1
Sub-Section Id :	8643511172
Question Shuffling Allowed :	Yes

Question Number : 21 Question Id : 86435120640 Question Type : SA
Correct Marks : 4 Wrong Marks : 0

The ratio of the equivalent resistance of the network (shown in figure) between the points a and b when switch is open and switch is closed is $x : 8$. The value of x is _____.

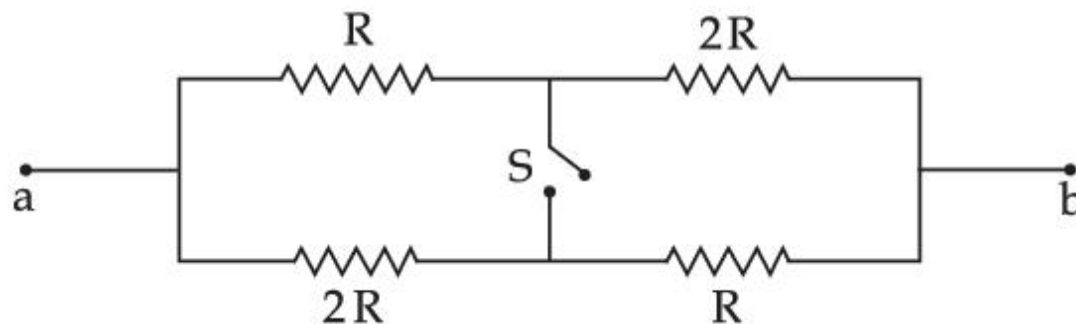

Response Type : Numeric

Evaluation Required For SA : Yes

Show Word Count : Yes

Answers Type : Equal

Text Areas : PlainText

Possible Answers :

1

Question Number : 22 **Question Id :** 86435120641 **Question Type :** SA

Correct Marks : 4 **Wrong Marks :** 0

An ac circuit has an inductor and a resistor of resistance R in series, such that $X_L = 3 R$. Now, a capacitor is added in series such that $X_C = 2 R$. The ratio of new power factor with the old power factor of the circuit is $\sqrt{5} : x$. The value of x is _____.

Response Type : Numeric

Evaluation Required For SA : Yes

Show Word Count : Yes

Answers Type : Equal

Text Areas : PlainText

Possible Answers :

1

Question Number : 23 **Question Id :** 86435120642 **Question Type :** SA

Correct Marks : 4 **Wrong Marks :** 0

A bullet of 10 g, moving with velocity v , collides head-on with the stationary bob of a pendulum and recoils with velocity 100 m/s. The length of the pendulum is 0.5 m and mass of the bob is 1 kg. The minimum value of $v =$ _____ m/s so that the pendulum describes a circle.

(Assume the string to be inextensible and $g = 10 \text{ m/s}^2$)

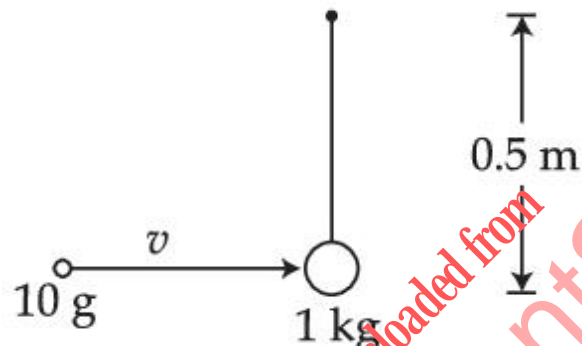

Response Type : Numeric

Evaluation Required For SA : Yes

Show Word Count : Yes

Answers Type : Equal

Text Areas : PlainText

Possible Answers :

1

Question Number : 24 Question Id : 86435120643 Question Type : SA

Correct Marks : 4 Wrong Marks : 0

Wires W_1 and W_2 are made of same material having the breaking stress of $1.25 \times 10^9 \text{ N/m}^2$. W_1 and W_2 have cross-sectional area of $8 \times 10^{-7} \text{ m}^2$ and $4 \times 10^{-7} \text{ m}^2$, respectively. Masses of 20 kg and 10 kg hang from them as shown in the figure. The maximum mass that can be placed in the pan without breaking the wires is _____ kg. (Use $g = 10 \text{ m/s}^2$)

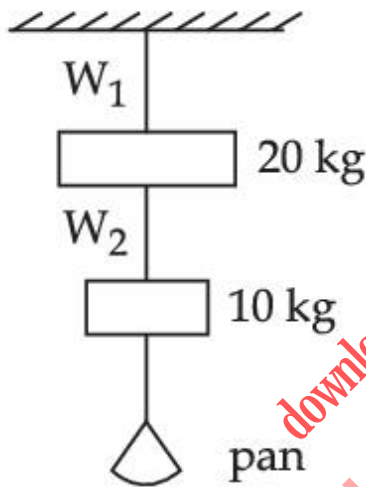

Response Type : Numeric

Evaluation Required For SA : Yes

Show Word Count : Yes

Answers Type : Equal

Text Areas : PlainText

Possible Answers :

1

Question Number : 25 Question Id : 86435120644 Question Type : SA

Correct Marks : 4 Wrong Marks : 0

A tuning fork is vibrating at 250 Hz. The length of the shortest closed organ pipe that will resonate with the tuning fork will be _____ cm.

(Take speed of sound in air as 340 ms^{-1})

Response Type : Numeric

Evaluation Required For SA : Yes

Show Word Count : Yes

Answers Type : Equal

Text Areas : PlainText

Possible Answers :

1

Question Number : 26 **Question Id :** 86435120645 **Question Type :** SA

Correct Marks : 4 **Wrong Marks :** 0

A heat engine operates between a cold reservoir at temperature $T_2 = 400$ K and a hot reservoir at temperature T_1 . It takes 300 J of heat from the hot reservoir and delivers 240 J of heat to the cold reservoir in a cycle. The minimum temperature of the hot reservoir has to be _____ K.

Response Type : Numeric

Evaluation Required For SA : Yes

Show Word Count : Yes

Answers Type : Equal

Text Areas : PlainText

Possible Answers :

1

Question Number : 27 **Question Id :** 86435120646 **Question Type :** SA

Correct Marks : 4 **Wrong Marks :** 0

Two simple harmonic motion, are represented by the equations

$$y_1 = 10 \sin\left(3\pi t + \frac{\pi}{3}\right)$$

$$y_2 = 5 (\sin 3\pi t + \sqrt{3} \cos 3\pi t)$$

Ratio of amplitude of y_1 to $y_2 = x : 1$. The value of x is _____.

Response Type : Numeric

Evaluation Required For SA : Yes

Show Word Count : Yes

Answers Type : Equal

Text Areas : PlainText

Possible Answers :

1

Question Number : 28 **Question Id :** 86435120647 **Question Type :** SA

Correct Marks : 4 **Wrong Marks :** 0

A plane electromagnetic wave with frequency of 30 MHz travels in free space. At particular point in space and time, electric field is 6 V/m. The magnetic field at this point will be $x \times 10^{-8}$ T. The value of x is _____.

Response Type : Numeric

Evaluation Required For SA : Yes

Show Word Count : Yes

Answers Type : Equal

Text Areas : PlainText

Possible Answers :

1

Question Number : 29 **Question Id :** 86435120648 **Question Type :** SA

Correct Marks : 4 **Wrong Marks :** 0

X different wavelengths may be observed in the spectrum from a hydrogen sample if the atoms are excited to states with principal quantum number $n=6$? The value of X is _____.

Response Type : Numeric

Evaluation Required For SA : Yes

Show Word Count : Yes

Answers Type : Equal

Text Areas : PlainText

Possible Answers :

1

Question Number : 30 **Question Id :** 86435120649 **Question Type :** SA

Correct Marks : 4 **Wrong Marks :** 0

A zener diode of power rating 2 W is to be used as a voltage regulator. If the zener diode has a breakdown of 10 V and it has to regulate voltage fluctuated between 6 V and 14 V, the value of R_S for safe operation should be _____ Ω .

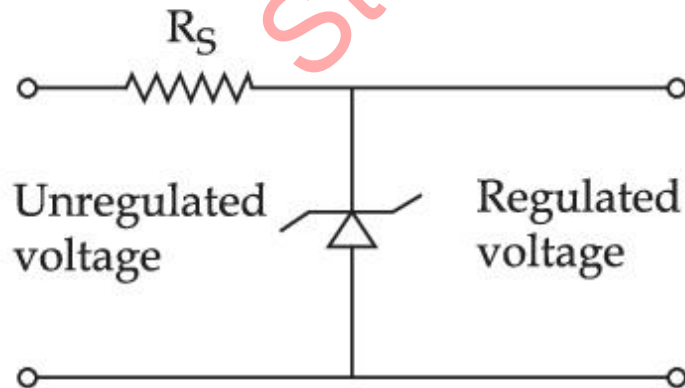

Response Type : Numeric

Evaluation Required For SA : Yes

Show Word Count : Yes

Answers Type : Equal

Text Areas : PlainText

Possible Answers :

1

Chemistry Section A

Section Id :	864351946
Section Number :	3
Section type :	Online
Mandatory or Optional :	Mandatory
Number of Questions :	20
Number of Questions to be attempted :	20
Section Marks :	80
Enable Mark as Answered Mark for Review and Clear Response :	Yes
Sub-Section Number :	1
Sub-Section Id :	8643511173
Question Shuffling Allowed :	Yes

Question Number : 31 Question Id : 86435120650 Question Type : MCQ Option Shuffling : Yes Is Question Mandatory : No
Correct Marks : 4 Wrong Marks : 1

Lyophilic sols are more stable than lyophobic sols because,

Options :

86435168531. the colloidal particles have positive charge.

86435168532. the colloidal particles have no charge.

86435168533. the colloidal particles are solvated.

86435168534.

there is a strong electrostatic repulsion between the negatively charged colloidal particles.

Question Number : 32 Question Id : 86435120651 Question Type : MCQ Option Shuffling : Yes Is Question Mandatory : No
Correct Marks : 4 Wrong Marks : 1

The correct order of ionic radii for the ions, P^{3-} , S^{2-} , Ca^{2+} , K^+ , Cl^- is :

Options :

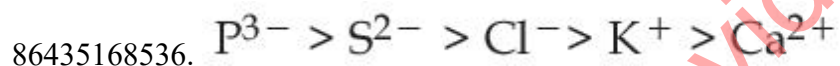
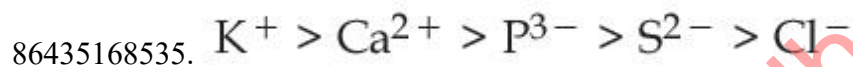

Question Number : 33 Question Id : 86435120652 Question Type : MCQ Option Shuffling : Yes Is Question Mandatory : No
Correct Marks : 4 Wrong Marks : 1

Match List - I with List - II :

List - I

(Name of ore/mineral)

- (a) Calamine
- (b) Malachite
- (c) Siderite
- (d) Sphalerite

List - II

(Chemical formula)

- (i) ZnS
- (ii) $FeCO_3$
- (iii) $ZnCO_3$
- (iv) $CuCO_3 \cdot Cu(OH)_2$

Choose the **most appropriate** answer from the options given below :

Options :

86435168539. (a)-(iii), (b)-(ii), (c)-(iv), (d)-(i)

86435168540. (a)-(iii), (b)-(iv), (c)-(ii), (d)-(i)

86435168541. (a)-(iii), (b)-(iv), (c)-(i), (d)-(ii)

86435168542. (a)-(iv), (b)-(iii), (c)-(i), (d)-(ii)

Question Number : 34 Question Id : 86435120653 Question Type : MCQ Option Shuffling : Yes Is Question Mandatory : No Correct Marks : 4 Wrong Marks : 1

The oxide that gives H_2O_2 most readily on treatment with H_2O is :

Options :

86435168543. PbO_2

86435168544. $\text{BaO}_2 \cdot 8\text{H}_2\text{O}$

86435168545. Na_2O_2

86435168546. SnO_2

Question Number : 35 Question Id : 86435120654 Question Type : MCQ Option Shuffling : Yes Is Question Mandatory : No Correct Marks : 4 Wrong Marks : 1

Choose the **correct** statement from the following :

Options :

86435168547. Among the alkali metal halides, LiF is least soluble in water.

86435168548.

LiF has least negative standard enthalpy of formation among alkali metal fluorides.

86435168549. The low solubility of CsI in water is due to its high lattice enthalpy.

86435168550.

The standard enthalpy of formation for alkali metal bromides becomes less negative on descending the group.

Question Number : 36 Question Id : 86435120655 Question Type : MCQ Option Shuffling : Yes Is Question Mandatory : No

Correct Marks : 4 Wrong Marks : 1

Which one of the following is formed (mainly) when red phosphorus is heated in a sealed tube at 803 K ?

Options :

86435168551. β -Black phosphorus

86435168552. α -Black phosphorus

86435168553. White phosphorus

86435168554. Yellow phosphorus

Question Number : 37 Question Id : 86435120656 Question Type : MCQ Option Shuffling : Yes Is Question Mandatory : No
Correct Marks : 4 Wrong Marks : 1

Potassium permanganate on heating at 513 K gives a product which is :

Options :

86435168555. paramagnetic and colourless

86435168556. diamagnetic and colourless

86435168557. paramagnetic and green

86435168558. diamagnetic and green

Question Number : 38 Question Id : 86435120657 Question Type : MCQ Option Shuffling : Yes Is Question Mandatory : No
Correct Marks : 4 Wrong Marks : 1

Which one of the following is used to remove most of plutonium from spent nuclear fuel ?

Options :

86435168559. I_2O_5

86435168560. BrO_3

86435168561. ClF_3

86435168562. O_2F_2

Question Number : 39 Question Id : 86435120658 Question Type : MCQ Option Shuffling : Yes Is Question Mandatory : No Correct Marks : 4 Wrong Marks : 1

In stratosphere most of the ozone formation is assisted by :

Options :

86435168563. γ -rays.

86435168564. visible radiations.

86435168565. ultraviolet radiation.

86435168566. cosmic rays.

Question Number : 40 Question Id : 86435120659 Question Type : MCQ Option Shuffling : Yes Is Question Mandatory : No Correct Marks : 4 Wrong Marks : 1

Which one of the following tests used for the identification of functional groups in organic compounds does not use copper reagent ?

Options :

86435168567. Biuret test for peptide bond

86435168568. Barfoed's test

86435168569. Seliwanoff's test

86435168570. Benedict's test

Question Number : 41 Question Id : 86435120660 Question Type : MCQ Option Shuffling : Yes Is Question Mandatory : No Correct Marks : 4 Wrong Marks : 1

The major product of the following reaction, if it occurs by S_N2 mechanism is :

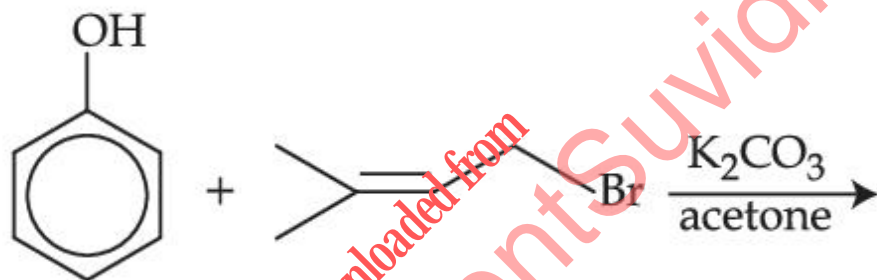

Options :

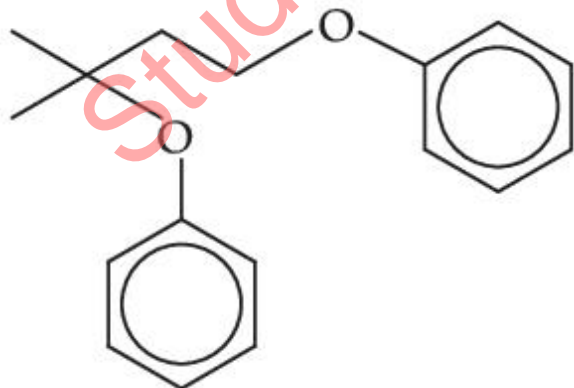

86435168571.

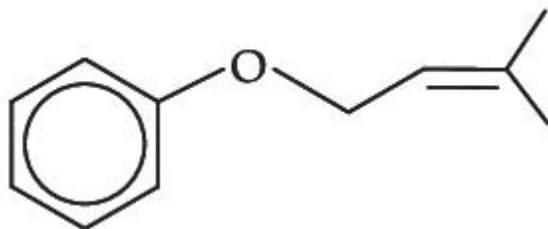

86435168572.

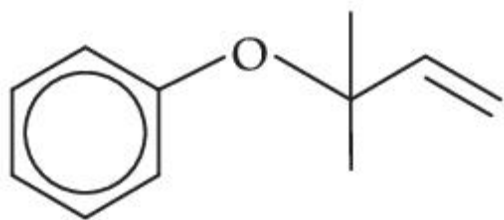

86435168573.

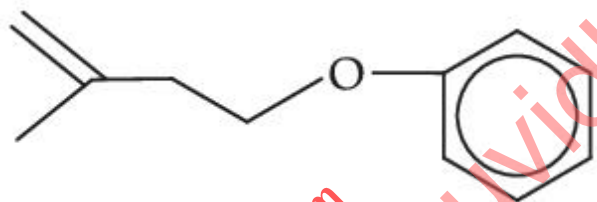

86435168574.

Question Number : 42 Question Id : 86435120661 Question Type : MCQ Option Shuffling : Yes Is Question Mandatory : No
 Correct Marks : 4 Wrong Marks : 1

Which one of the following reactions will **not** yield propionic acid ?

Options :

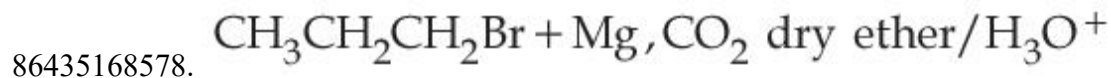
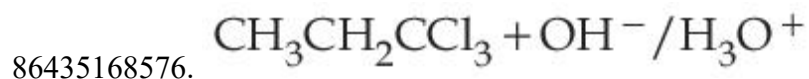

Question Number : 43 Question Id : 86435120662 Question Type : MCQ Option Shuffling : Yes Is Question Mandatory : No

Correct Marks : 4 Wrong Marks : 1

The major product (A) formed in the reaction given below is :

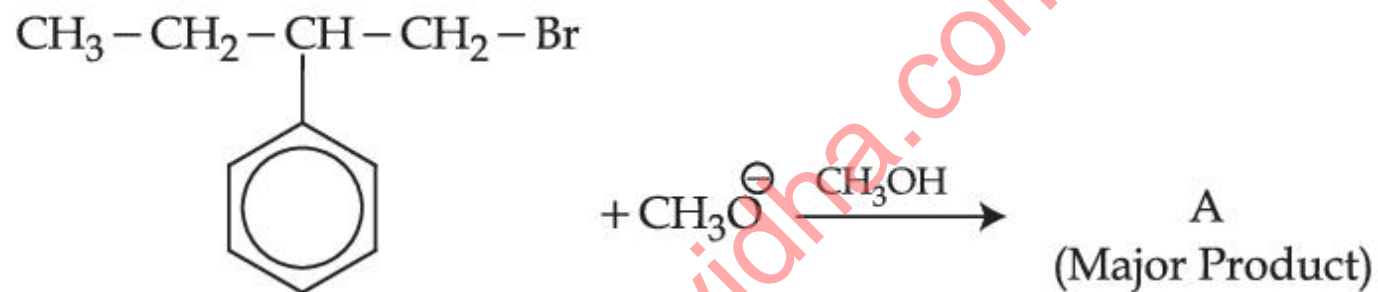

Options :

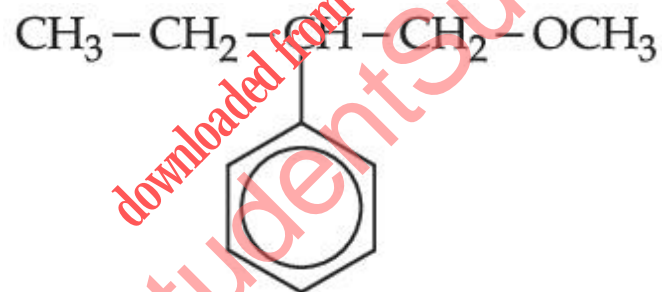

86435168579.

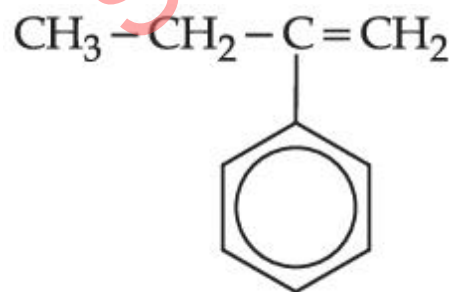

86435168580.

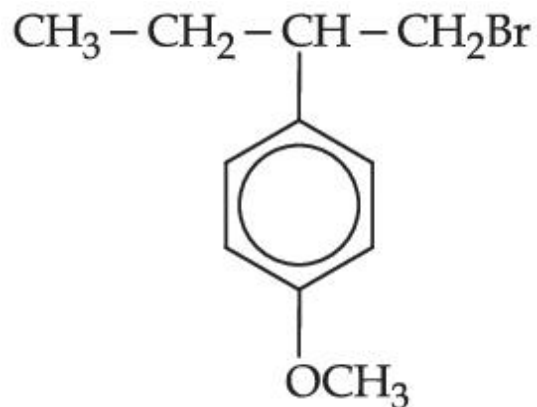

86435168581.

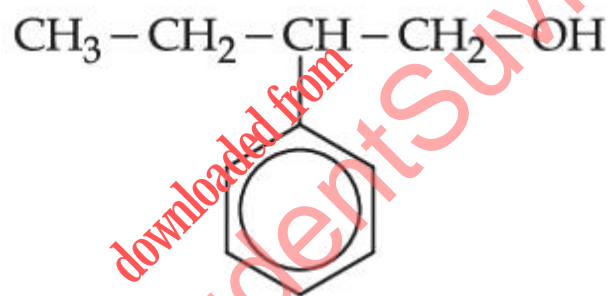

86435168582.

Question Number : 44 Question Id : 86435120663 Question Type : MCQ Option Shuffling : Yes Is Question Mandatory : No
Correct Marks : 4 Wrong Marks : 1

Which one of the following is the major product of the given reaction ?

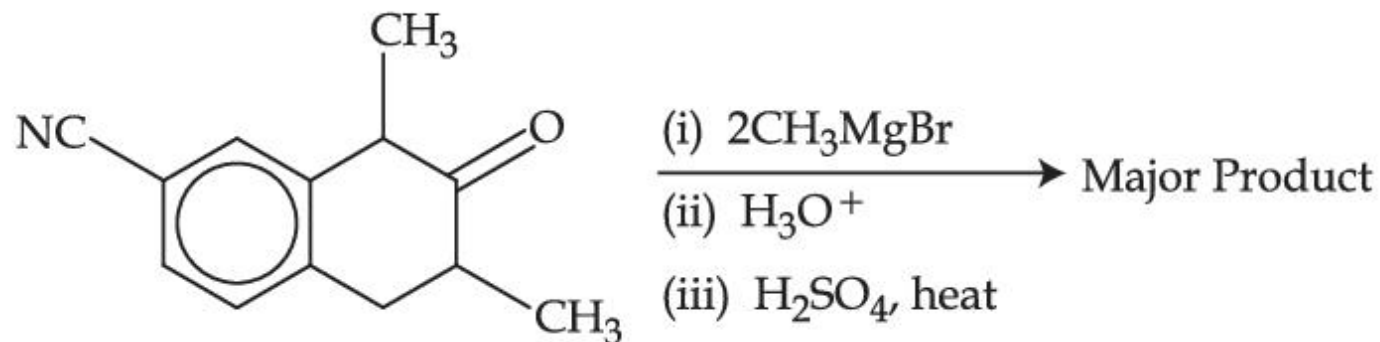

Options :

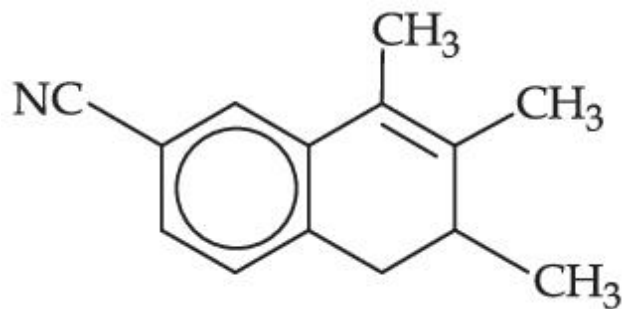

86435168583.

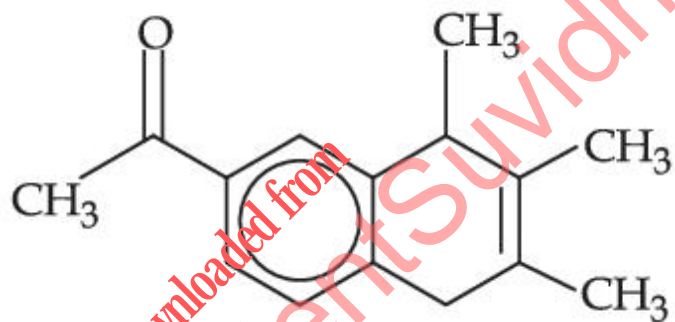

86435168584.



86435168585.

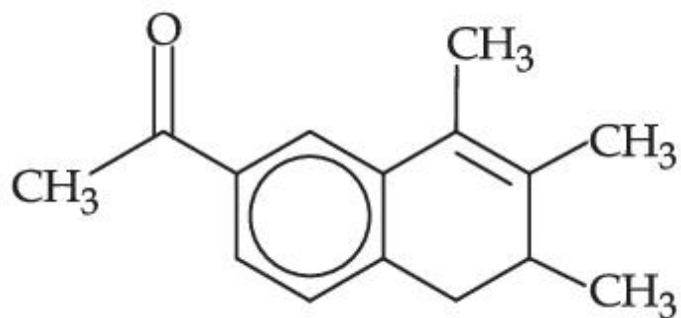

86435168586.

Question Number : 45 Question Id : 86435120664 Question Type : MCQ Option Shuffling : Yes Is Question Mandatory : No

Correct Marks : 4 Wrong Marks : 1

Given below are two statements :

Statement I : Ethyl pent-4-yn-oate on reaction with CH_3MgBr gives a 3° -alcohol.

Statement II : In this reaction one mole of ethyl pent-4-yn-oate utilizes two moles of CH_3MgBr .

In the light of the above statements, choose the **most appropriate** answer from the options given below :

Options :

86435168587. Both **Statement I** and **Statement II** are true

86435168588. Both **Statement I** and **Statement II** are false

86435168589. **Statement I** is true but **Statement II** is false

86435168590. **Statement I** is false but **Statement II** is true

Question Number : 46 Question Id : 86435120665 Question Type : MCQ Option Shuffling : Yes Is Question Mandatory : No

Correct Marks : 4 Wrong Marks : 1

The compound/s which will show significant intermolecular H-bonding is/are :

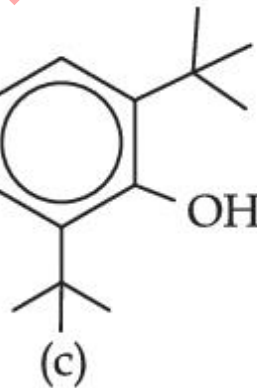
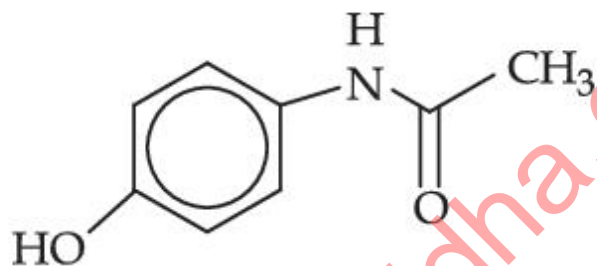
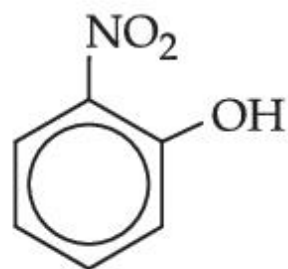

Options :

86435168591. (a), (b) and (c)

86435168592. (a) and (b) only

86435168593. (b) only

86435168594. (c) only

Question Number : 47 Question Id : 86435120666 Question Type : MCQ Option Shuffling : Yes Is Question Mandatory : No
Correct Marks : 4 Wrong Marks : 1

The correct structures of **A** and **B** formed in the following reactions are :

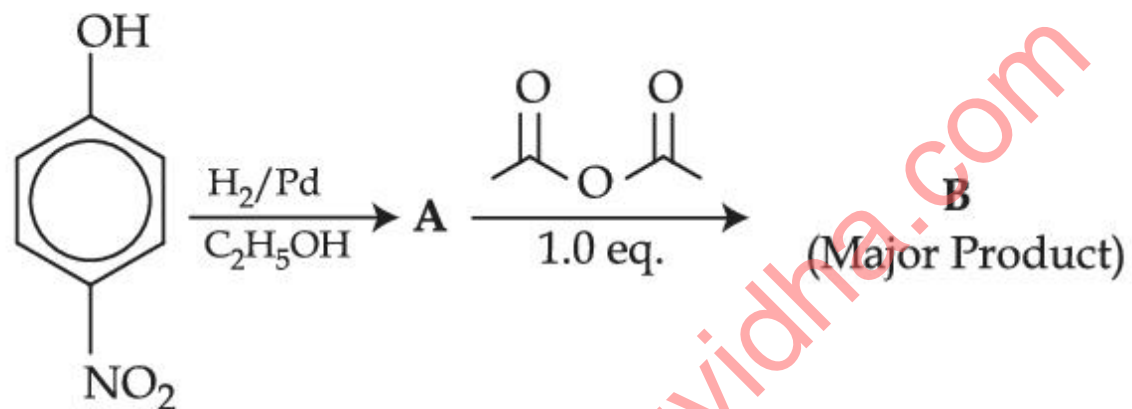

Options :

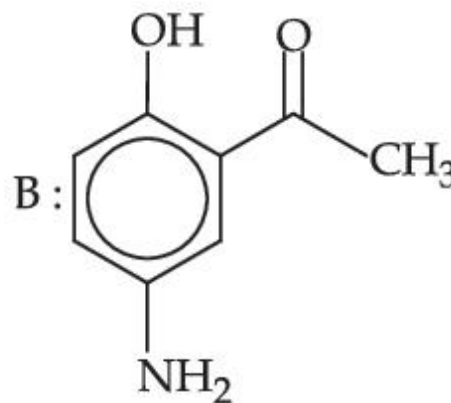
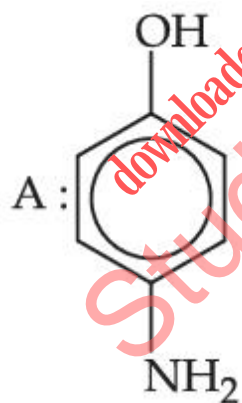

86435168595.

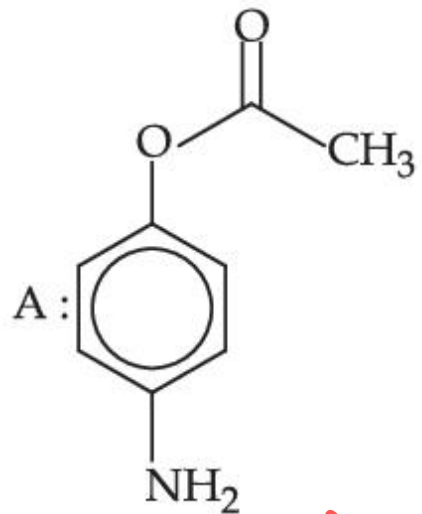

,

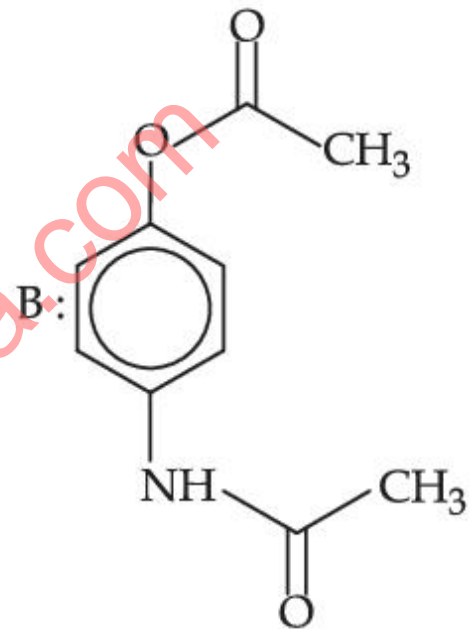

86435168596.

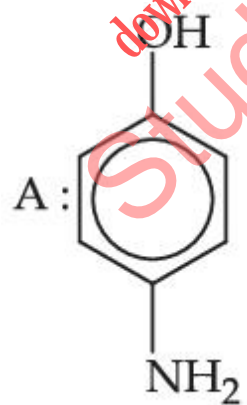

,

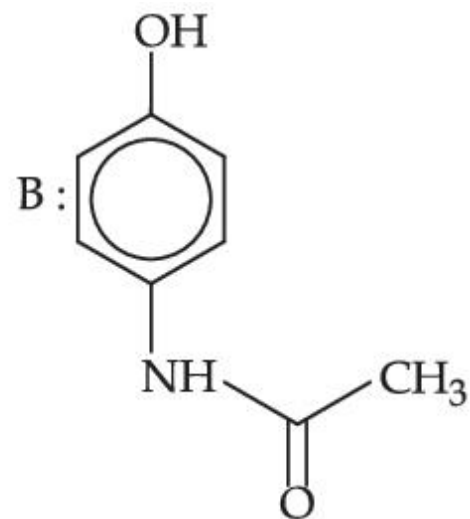

86435168597.

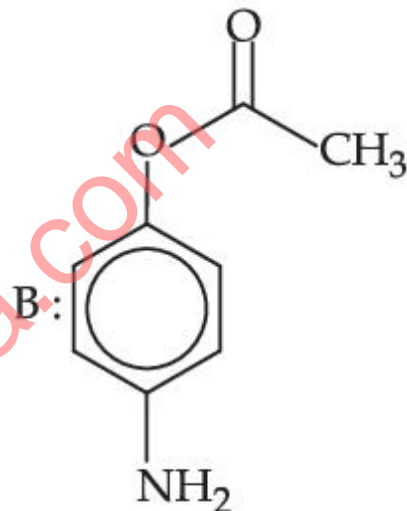
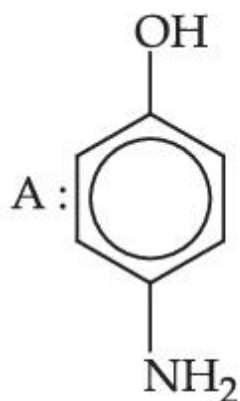

86435168598.

Question Number : 48 Question Id : 86435120667 Question Type : MCQ Option Shuffling : Yes Is Question Mandatory : No

Correct Marks : 4 Wrong Marks : 1

Which one of the following chemicals is responsible for the production of HCl in the stomach leading to irritation and pain ?

Options :

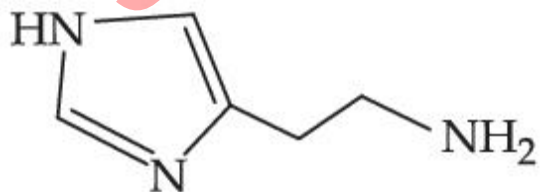

86435168599.

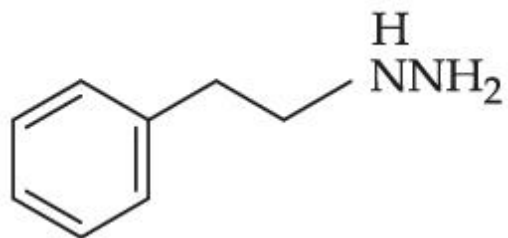

86435168600.

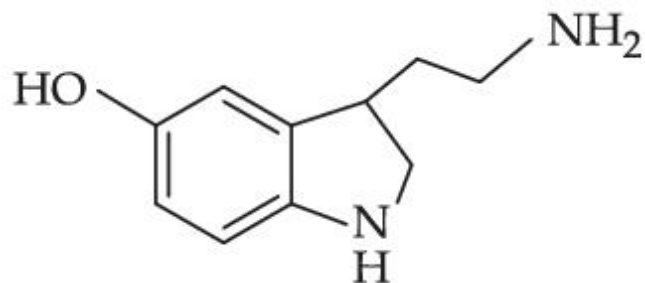

86435168601.

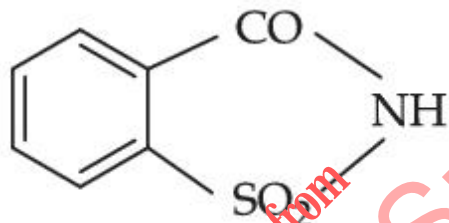

86435168602.

Question Number : 49 Question Id : 86435120668 Question Type : MCQ Option Shuffling : Yes Is Question Mandatory : No
 Correct Marks : 4 Wrong Marks : 1

Hydrolysis of sucrose gives :

Options :

86435168603. α -D-(-)-Glucose and β -D-(-)-Fructose

86435168604. α -D-(+)-Glucose and β -D-(-)-Fructose

86435168605. α -D-(+)-Glucose and α -D-(-)-Fructose

86435168606. α -D-(-)-Glucose and α -D-(+)-Fructose

Question Number : 50 Question Id : 86435120669 Question Type : MCQ Option Shuffling : Yes Is Question Mandatory : No

Correct Marks : 4 Wrong Marks : 1

The addition of dilute NaOH to Cr^{3+} salt solution will give :

Options :

86435168607. a solution of $[\text{Cr}(\text{OH})_4]^-$

86435168608. precipitate of $\text{Cr}(\text{OH})_3$

86435168609. precipitate of $\text{Cr}_2\text{O}_3(\text{H}_2\text{O})_n$

86435168610. precipitate of $[\text{Cr}(\text{OH})_6]^{3-}$

Chemistry Section B

Section Id :	864351947
Section Number :	4
Section type :	Online
Mandatory or Optional :	Mandatory
Number of Questions :	10
Number of Questions to be attempted :	5
Section Marks :	20
Enable Mark as Answered Mark for Review and Clear Response :	Yes
Sub-Section Number :	1
Sub-Section Id :	8643511174
Question Shuffling Allowed :	Yes

Question Number : 51 Question Id : 86435120670 Question Type : SA

Correct Marks : 4 Wrong Marks : 0

100 g of propane is completely reacted with 1000 g of oxygen. The mole fraction of carbon dioxide in the resulting mixture is $x \times 10^{-2}$. The value of x is _____.

(Nearest integer)

[Atomic weight : H = 1.008; C = 12.00; O = 16.00]

Response Type : Numeric

Evaluation Required For SA : Yes

Show Word Count : Yes

Answers Type : Equal

Text Areas : PlainText

Possible Answers :

1

Question Number : 52 Question Id : 86435120671 Question Type : SA

Correct Marks : 4 Wrong Marks : 0

Two flasks I and II shown below are connected by a valve of negligible volume.

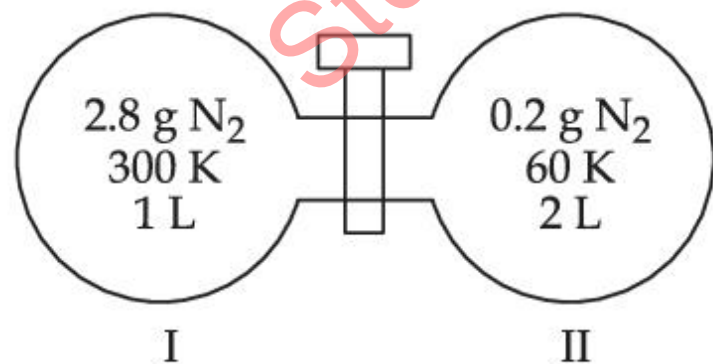

When the valve is opened, the final pressure of the system in bar is $x \times 10^{-2}$. The value of x is _____. (Integer answer)

[Assume - Ideal gas; 1 bar = 10^5 Pa; Molar mass of N₂ = 28.0 g mol⁻¹; R = 8.31 J mol⁻¹ K⁻¹]

Response Type : Numeric

Evaluation Required For SA : Yes

Show Word Count : Yes

Answers Type : Equal

Text Areas : PlainText

Possible Answers :

1

Question Number : 53 Question Id : 86435120672 Question Type : SA

Correct Marks : 4 Wrong Marks : 0

The number of photons emitted by a monochromatic (single frequency) infrared range finder of power 1 mW and wavelength of 1000 nm, in 0.1 second is $x \times 10^{13}$. The value of x is _____ . (Nearest integer)

$$(h = 6.63 \times 10^{-34} \text{ Js}, c = 3.00 \times 10^8 \text{ ms}^{-1})$$

Response Type : Numeric

Evaluation Required For SA : Yes

Show Word Count : Yes

Answers Type : Equal

Text Areas : PlainText

Possible Answers :

1

Question Number : 54 Question Id : 86435120673 Question Type : SA

Correct Marks : 4 Wrong Marks : 0

The number of species having non-pyramidal shape among the following is _____.

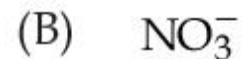

Response Type : Numeric

Evaluation Required For SA : Yes

Show Word Count : Yes

Answers Type : Equal

Text Areas : PlainText

Possible Answers :

1

Question Number : 55 **Question Id :** 86435120674 **Question Type :** SA

Correct Marks : 4 **Wrong Marks :** 0

Data given for the following reaction is as follows :

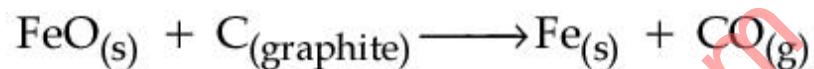

Substance	$\Delta_f H^\circ$ (kJ mol ⁻¹)	ΔS° (J mol ⁻¹ K ⁻¹)
FeO _(s)	-266.3	57.49
C _(graphite)	0	5.74
Fe _(s)	0	27.28
CO _(g)	-110.5	197.6

The minimum temperature in K at which the reaction becomes spontaneous is _____.

(Integer answer)

Response Type : Numeric

Evaluation Required For SA : Yes

Show Word Count : Yes

Answers Type : Equal

Text Areas : PlainText

Possible Answers :

1

Question Number : 56 Question Id : 86435120675 Question Type : SA

Correct Marks : 4 Wrong Marks : 0

40 g of glucose (Molar mass = 180) is mixed with 200 mL of water. The freezing point of solution is _____ K. (Nearest integer)

[Given : $K_f = 1.86 \text{ K kg mol}^{-1}$; Density of water = 1.00 g cm^{-3} ; Freezing point of water = 273.15 K]

Response Type : Numeric

Evaluation Required For SA : Yes

Show Word Count : Yes

Answers Type : Equal

Text Areas : PlainText

Possible Answers :

1

Question Number : 57 Question Id : 86435120676 Question Type : SA

Correct Marks : 4 Wrong Marks : 0

When 5.1 g of solid NH_4HS is introduced into a two litre evacuated flask at 27°C , 20% of the solid decomposes into gaseous ammonia and hydrogen sulphide. The K_p for the reaction at 27°C is $x \times 10^{-2}$. The value of x is _____. (Integer answer)

[Given $R = 0.082 \text{ L atm K}^{-1} \text{ mol}^{-1}$]

Response Type : Numeric

Evaluation Required For SA : Yes

Show Word Count : Yes

Answers Type : Equal

Text Areas : PlainText

Possible Answers :

1

Question Number : 58 Question Id : 86435120677 Question Type : SA

Correct Marks : 4 Wrong Marks : 0

The resistance of a conductivity cell with cell constant 1.14 cm^{-1} , containing 0.001 M KCl at 298 K is 1500Ω . The molar conductivity of 0.001 M KCl solution at 298 K in $\text{S cm}^2 \text{ mol}^{-1}$ is _____. (Integer answer)

Response Type : Numeric

Evaluation Required For SA : Yes

Show Word Count : Yes

Answers Type : Equal

Text Areas : PlainText

Possible Answers :

1

Question Number : 59 Question Id : 86435120678 Question Type : SA

Correct Marks : 4 Wrong Marks : 0

The first order rate constant for the decomposition of CaCO_3 at 700 K is $6.36 \times 10^{-3} \text{ s}^{-1}$ and activation energy is 209 kJ mol^{-1} . Its rate constant (in s^{-1}) at 600 K is $x \times 10^{-6}$. The value of x is _____. (Nearest integer)

[Given $R = 8.31 \text{ J K}^{-1} \text{ mol}^{-1}$; $\log 6.36 \times 10^{-3} = -2.19$, $10^{-4.79} = 1.62 \times 10^{-5}$]

Response Type : Numeric

Evaluation Required For SA : Yes

Show Word Count : Yes

Answers Type : Equal

Text Areas : PlainText

Possible Answers :

1

Question Number : 60 Question Id : 86435120679 Question Type : SA

Correct Marks : 4 Wrong Marks : 0

The number of optical isomers possible for $[\text{Cr}(\text{C}_2\text{O}_4)_3]^{3-}$ is _____.

Response Type : Numeric
Evaluation Required For SA : Yes
Show Word Count : Yes
Answers Type : Equal
Text Areas : PlainText
Possible Answers :
1

Mathematics Section A

Section Id :	864351948
Section Number :	5
Section type :	Online
Mandatory or Optional :	Mandatory
Number of Questions :	20
Number of Questions to be attempted :	20
Section Marks :	80
Enable Mark as Answered Mark for Review and Clear Response :	Yes
Sub-Section Number :	1
Sub-Section Id :	8643511175
Question Shuffling Allowed :	Yes

Question Number : 61 Question Id : 86435120680 Question Type : MCQ Option Shuffling : Yes Is Question Mandatory : No
Correct Marks : 4 Wrong Marks : 1

Let \mathbb{Z} be the set of all integers,

$$A = \{(x, y) \in \mathbb{Z} \times \mathbb{Z} : (x - 2)^2 + y^2 \leq 4\},$$

$$B = \{(x, y) \in \mathbb{Z} \times \mathbb{Z} : x^2 + y^2 \leq 4\} \text{ and}$$

$$C = \{(x, y) \in \mathbb{Z} \times \mathbb{Z} : (x - 2)^2 + (y - 2)^2 \leq 4\}$$

If the total number of relations from $A \cap B$ to $A \cap C$ is 2^p , then the value of p is :

Options :

86435168621. 9

86435168622. 16

86435168623. 25

86435168624. 49

Question Number : 62 Question Id : 86435120681 Question Type : MCQ Option Shuffling : Yes Is Question Mandatory : No

Correct Marks : 4 Wrong Marks : 1

The set of all values of $k > -1$, for which the equation

$$(3x^2 + 4x + 3)^2 - (k + 1)(3x^2 + 4x + 3)(3x^2 + 4x + 2) + k(3x^2 + 4x + 2)^2 = 0 \text{ has real roots, is :}$$

Options :

86435168625. $\left(1, \frac{5}{2}\right]$

86435168626. $[2, 3)$

86435168627. $\left[-\frac{1}{2}, 1\right)$

86435168628. $\left(\frac{1}{2}, \frac{3}{2}\right] - \left\{\frac{1}{2}\right\}$

Question Number : 63 Question Id : 86435120682 Question Type : MCQ Option Shuffling : Yes Is Question Mandatory : No
Correct Marks : 4 Wrong Marks : 1

Let $[\lambda]$ be the greatest integer less than or equal to λ . The set of all values of λ for which the system of linear equations $x + y + z = 4$, $3x + 2y + 5z = 3$, $9x + 4y + (28 + [\lambda])z = [\lambda]$ has a solution is :

Options :

86435168629. $[-9, -8)$

86435168630. $(-\infty, -9) \cup [-8, \infty)$

86435168631. \mathbf{R}

86435168632. $(-\infty, -9) \cup (-9, \infty)$

Question Number : 64 Question Id : 86435120683 Question Type : MCQ Option Shuffling : Yes Is Question Mandatory : No
Correct Marks : 4 Wrong Marks : 1

Let $A = \begin{pmatrix} [x + 1] & [x + 2] & [x + 3] \\ [x] & [x + 3] & [x + 3] \\ [x] & [x + 2] & [x + 4] \end{pmatrix}$, where $[t]$ denotes the greatest integer less than or equal

to t . If $\det(A) = 192$, then the set of values of x is the interval :

Options :

86435168633. $[68, 69)$

86435168634. $[65, 66)$

86435168635. $[62, 63)$

86435168636. $[60, 61)$

Question Number : 65 Question Id : 86435120684 Question Type : MCQ Option Shuffling : Yes Is Question Mandatory : No
Correct Marks : 4 Wrong Marks : 1

If $0 < x < 1$ and $y = \frac{1}{2}x^2 + \frac{2}{3}x^3 + \frac{3}{4}x^4 + \dots$, then the value of e^{1+y} at $x = \frac{1}{2}$ is :

Options :

86435168637. $2e$

86435168638. $2e^2$

86435168639. $\frac{1}{2}\sqrt{e}$

86435168640. $\frac{1}{2}e^2$

Question Number : 66 Question Id : 86435120685 Question Type : MCQ Option Shuffling : Yes Is Question Mandatory : No
Correct Marks : 4 Wrong Marks : 1

If $\lim_{x \rightarrow \infty} (\sqrt{x^2 - x} - 1 - ax) = b$, then the ordered pair (a, b) is :

Options :

86435168641. $\left(-1, -\frac{1}{2}\right)$

86435168642. $\left(1, -\frac{1}{2}\right)$

86435168643. $\left(1, \frac{1}{2}\right)$

86435168644. $\left(-1, \frac{1}{2}\right)$

Question Number : 67 Question Id : 86435120686 Question Type : MCQ Option Shuffling : Yes Is Question Mandatory : No Correct Marks : 4 Wrong Marks : 1

If $y(x) = \cot^{-1}\left(\frac{\sqrt{1+\sin x} + \sqrt{1-\sin x}}{\sqrt{1+\sin x} - \sqrt{1-\sin x}}\right)$, $x \in \left(\frac{\pi}{2}, \pi\right)$, then $\frac{dy}{dx}$ at $x = \frac{5\pi}{6}$ is :

Options :

86435168645. $\frac{1}{2}$

86435168646. $-\frac{1}{2}$

86435168647. 0

86435168648. -1

Question Number : 68 Question Id : 86435120687 Question Type : MCQ Option Shuffling : Yes Is Question Mandatory : No Correct Marks : 4 Wrong Marks : 1

Let M and m respectively be the maximum and minimum values of the function

$f(x) = \tan^{-1}(\sin x + \cos x)$ in $\left[0, \frac{\pi}{2}\right]$. Then the value of $\tan(M - m)$ is equal to :

Options :

86435168649. $2 + \sqrt{3}$

86435168650. $2 - \sqrt{3}$

86435168651. $3 - 2\sqrt{2}$

86435168652. $3 + 2\sqrt{2}$

Question Number : 69 Question Id : 86435120688 Question Type : MCQ Option Shuffling : Yes Is Question Mandatory : No

Correct Marks : 4 Wrong Marks : 1

A box open from top is made from a rectangular sheet of dimension $a \times b$ by cutting squares each of side x from each of the four corners and folding up the flaps. If the volume of the box is maximum, then x is equal to :

Options :

86435168653.
$$\frac{a + b - \sqrt{a^2 + b^2 - ab}}{6}$$

86435168654.
$$\frac{a + b - \sqrt{a^2 + b^2 - ab}}{12}$$

86435168655.
$$\frac{a + b - \sqrt{a^2 + b^2 + ab}}{6}$$

86435168656.
$$\frac{a + b + \sqrt{a^2 + b^2 - ab}}{6}$$

Question Number : 70 Question Id : 86435120689 Question Type : MCQ Option Shuffling : Yes Is Question Mandatory : No Correct Marks : 4 Wrong Marks : 1

The value of the integral $\int_0^1 \frac{\sqrt{x} dx}{(1+x)(1+3x)(3+x)}$ is :

Options :

86435168657.
$$\frac{\pi}{8} \left(1 - \frac{\sqrt{3}}{2} \right)$$

86435168658.
$$\frac{\pi}{8} \left(1 - \frac{\sqrt{3}}{6} \right)$$

86435168659.
$$\frac{\pi}{4} \left(1 - \frac{\sqrt{3}}{6} \right)$$

86435168660. $\frac{\pi}{4} \left(1 - \frac{\sqrt{3}}{2} \right)$

Question Number : 71 Question Id : 86435120690 Question Type : MCQ Option Shuffling : Yes Is Question Mandatory : No Correct Marks : 4 Wrong Marks : 1

The area of the region bounded by the parabola $(y - 2)^2 = (x - 1)$, the tangent to it at the point whose ordinate is 3 and the x -axis is :

Options :

86435168661. 6

86435168662. 9

86435168663. 10

86435168664. 4

Question Number : 72 Question Id : 86435120691 Question Type : MCQ Option Shuffling : Yes Is Question Mandatory : No Correct Marks : 4 Wrong Marks : 1

A differential equation representing the family of parabolas with axis parallel to y -axis and whose length of latus rectum is the distance of the point $(2, -3)$ from the line $3x + 4y = 5$, is given by :

Options :

86435168665. $11 \frac{d^2x}{dy^2} = 10$

86435168666. $10 \frac{d^2y}{dx^2} = 11$

86435168667. $11 \frac{d^2y}{dx^2} = 10$

86435168668. $10 \frac{d^2x}{dy^2} = 11$

Question Number : 73 Question Id : 86435120692 Question Type : MCQ Option Shuffling : Yes Is Question Mandatory : No Correct Marks : 4 Wrong Marks : 1

If the solution curve of the differential equation $(2x - 10y^3)dy + ydx = 0$, passes through the points $(0, 1)$ and $(2, \beta)$, then β is a root of the equation :

Options :

86435168669. $2y^5 - 2y - 1 = 0$

86435168670. $2y^5 - y^2 - 2 = 0$

86435168671. $y^5 - y^2 - 1 = 0$

86435168672. $y^5 - 2y - 2 = 0$

Question Number : 74 Question Id : 86435120693 Question Type : MCQ Option Shuffling : Yes Is Question Mandatory : No Correct Marks : 4 Wrong Marks : 1

Let $A(a, 0)$, $B(b, 2b + 1)$ and $C(0, b)$, $b \neq 0$, $|b| \neq 1$, be points such that the area of triangle ABC is 1 sq. unit, then the sum of all possible values of a is :

Options :

86435168673. $\frac{2b}{b + 1}$

86435168674. $\frac{-2b}{b + 1}$

86435168675. $\frac{2b^2}{b + 1}$

86435168676. $\frac{-2b^2}{b + 1}$

Question Number : 75 Question Id : 86435120694 Question Type : MCQ Option Shuffling : Yes Is Question Mandatory : No

Correct Marks : 4 Wrong Marks : 1

If two tangents drawn from a point P to the parabola $y^2 = 16(x - 3)$ are at right angles, then the locus of point P is :

Options :

86435168677. $x + 1 = 0$

86435168678. $x + 2 = 0$

86435168679. $x + 3 = 0$

86435168680. $x + 4 = 0$

Question Number : 76 Question Id : 86435120695 Question Type : MCQ Option Shuffling : Yes Is Question Mandatory : No

Correct Marks : 4 Wrong Marks : 1

The angle between the straight lines, whose direction cosines are given by the equations $2l + 2m - n = 0$ and $mn + nl + lm = 0$, is :

Options :

86435168681. $\frac{\pi}{3}$

86435168682. $\cos^{-1}\left(\frac{8}{9}\right)$

86435168683. $\frac{\pi}{2}$

$$\pi - \cos^{-1}\left(\frac{4}{9}\right)$$

86435168684.

Question Number : 77 Question Id : 86435120696 Question Type : MCQ Option Shuffling : Yes Is Question Mandatory : No Correct Marks : 4 Wrong Marks : 1

The equation of the plane passing through the line of intersection of the planes

$$\vec{r} \cdot (\hat{i} + \hat{j} + \hat{k}) = 1 \text{ and } \vec{r} \cdot (2\hat{i} + 3\hat{j} - \hat{k}) + 4 = 0 \text{ and parallel to the } x\text{-axis is :}$$

Options :

86435168685. $\vec{r} \cdot (\hat{i} - 3\hat{k}) + 6 = 0$

86435168686. $\vec{r} \cdot (\hat{i} + 3\hat{k}) + 6 = 0$

86435168687. $\vec{r} \cdot (\hat{j} - 3\hat{k}) - 6 = 0$

86435168688. $\vec{r} \cdot (\hat{j} - 3\hat{k}) + 6 = 0$

Question Number : 78 Question Id : 86435120697 Question Type : MCQ Option Shuffling : Yes Is Question Mandatory : No Correct Marks : 4 Wrong Marks : 1

Each of the persons A and B independently tosses three fair coins. The probability that both of them get the same number of heads is :

Options :

86435168689. $\frac{5}{8}$

86435168690. $\frac{1}{8}$

86435168691. $\frac{5}{16}$

86435168692. 1

Question Number : 79 Question Id : 86435120698 Question Type : MCQ Option Shuffling : Yes Is Question Mandatory : No Correct Marks : 4 Wrong Marks : 1

The Boolean expression $(p \wedge q) \Rightarrow ((r \wedge q) \wedge p)$ is equivalent to :

Options :

86435168693. $(q \wedge r) \Rightarrow (p \wedge q)$

86435168694. $(p \wedge q) \Rightarrow (r \wedge q)$

86435168695. $(p \wedge q) \Rightarrow (r \vee q)$

86435168696. $(p \wedge r) \Rightarrow (p \wedge q)$

Question Number : 80 Question Id : 86435120699 Question Type : MCQ Option Shuffling : Yes Is Question Mandatory : No Correct Marks : 4 Wrong Marks : 1

Two poles, AB of length a metres and CD of length a + b (b ≠ a) metres are erected at the same horizontal level with bases at B and D. If BD = x and $\tan \angle ACB = \frac{1}{2}$, then :

Options :

86435168697. $x^2 + 2(a + 2b)x + b(a + b) = 0$

86435168698. $x^2 - 2ax + a(a + b) = 0$

86435168699. $x^2 - 2ax + b(a + b) = 0$

86435168700. $x^2 + 2(a + 2b)x + a(a + b) = 0$

Mathematics Section B

Section Id :	864351949
Section Number :	6
Section type :	Online
Mandatory or Optional :	Mandatory
Number of Questions :	10
Number of Questions to be attempted :	5
Section Marks :	20

Enable Mark as Answered Mark for Review and Clear Response : Yes
Sub-Section Number : 1
Sub-Section Id : 8643511176
Question Shuffling Allowed : Yes

Question Number : 81 Question Id : 86435120700 Question Type : SA
Correct Marks : 4 Wrong Marks : 0

Let z_1 and z_2 be two complex numbers such that $\arg(z_1 - z_2) = \frac{\pi}{4}$ and z_1, z_2 satisfy the equation $|z - 3| = \operatorname{Re}(z)$. Then the imaginary part of $z_1 + z_2$ is equal to _____.

Response Type : Numeric

Evaluation Required For SA : Yes

Show Word Count : Yes

Answers Type : Equal

Text Areas : PlainText

Possible Answers :

1

Question Number : 82 Question Id : 86435120701 Question Type : SA
Correct Marks : 4 Wrong Marks : 0

Let $S = \{1, 2, 3, 4, 5, 6, 9\}$. Then the number of elements in the set $T = \{A \subseteq S : A \neq \phi \text{ and the sum of all the elements of } A \text{ is not a multiple of } 3\}$ is _____.

Response Type : Numeric

Evaluation Required For SA : Yes

Show Word Count : Yes

Answers Type : Equal

Text Areas : PlainText

Possible Answers :

1

Question Number : 83 Question Id : 86435120702 Question Type : SA

Correct Marks : 4 Wrong Marks : 0

$3 \times 7^{22} + 2 \times 10^{22} - 44$ when divided by 18 leaves the remainder _____.

Response Type : Numeric

Evaluation Required For SA : Yes

Show Word Count : Yes

Answers Type : Equal

Text Areas : PlainText

Possible Answers :

1

Question Number : 84 Question Id : 86435120703 Question Type : SA

Correct Marks : 4 Wrong Marks : 0

If $\int \frac{2e^x + 3e^{-x}}{4e^x + 7e^{-x}} dx = \frac{1}{14} (ux + v \log_e(4e^x + 7e^{-x})) + C$, where C is a constant of integration, then $u + v$ is equal to _____.

Response Type : Numeric

Evaluation Required For SA : Yes

Show Word Count : Yes

Answers Type : Equal

Text Areas : PlainText

Possible Answers :

1

Question Number : 85 Question Id : 86435120704 Question Type : SA

Correct Marks : 4 Wrong Marks : 0

Two circles each of radius 5 units touch each other at the point $(1, 2)$. If the equation of their common tangent is $4x + 3y = 10$, and $C_1(\alpha, \beta)$ and $C_2(\gamma, \delta)$, $C_1 \neq C_2$ are their centres, then $|(\alpha + \beta)(\gamma + \delta)|$ is equal to _____.

Response Type : Numeric

Evaluation Required For SA : Yes

Show Word Count : Yes

Answers Type : Equal

Text Areas : PlainText

Possible Answers :

1

Question Number : 86 **Question Id :** 86435120705 **Question Type :** SA

Correct Marks : 4 **Wrong Marks :** 0

Let $A(\sec\theta, 2\tan\theta)$ and $B(\sec\phi, 2\tan\phi)$, where $\theta + \phi = \pi/2$, be two points on the hyperbola $2x^2 - y^2 = 2$. If (α, β) is the point of the intersection of the normals to the hyperbola at A and B , then $(2\beta)^2$ is equal to _____.

Response Type : Numeric

Evaluation Required For SA : Yes

Show Word Count : Yes

Answers Type : Equal

Text Areas : PlainText

Possible Answers :

1

Question Number : 87 **Question Id :** 86435120706 **Question Type :** SA

Correct Marks : 4 **Wrong Marks :** 0

Let S be the mirror image of the point $Q(1, 3, 4)$ with respect to the plane $2x - y + z + 3 = 0$ and let $R(3, 5, \gamma)$ be a point of this plane. Then the square of the length of the line segment SR is _____.

Response Type : Numeric

Evaluation Required For SA : Yes

Show Word Count : Yes

Answers Type : Equal

Text Areas : PlainText

Possible Answers :

1

Question Number : 88 **Question Id :** 86435120707 **Question Type :** SA

Correct Marks : 4 **Wrong Marks :** 0

The probability distribution of random variable X is given by :

X	1	2	3	4	5
P(X)	K	2K	2K	3K	K

Let $p = P(1 < X < 4 | X < 3)$. If $5p = \lambda K$, then λ is equal to _____.

Response Type : Numeric

Evaluation Required For SA : Yes

Show Word Count : Yes

Answers Type : Equal

Text Areas : PlainText

Possible Answers :

1

Question Number : 89 **Question Id :** 86435120708 **Question Type :** SA

Correct Marks : 4 **Wrong Marks :** 0

Let S be the sum of all solutions (in radians) of the equation $\sin^4\theta + \cos^4\theta - \sin\theta \cos\theta = 0$ in

$[0, 4\pi]$. Then $\frac{8S}{\pi}$ is equal to _____.

Response Type : Numeric

Evaluation Required For SA : Yes

Show Word Count : Yes

Answers Type : Equal

Text Areas : PlainText

Possible Answers :

1

Question Number : 90 **Question Id :** 86435120709 **Question Type :** SA

Correct Marks : 4 **Wrong Marks :** 0

An online exam is attempted by 50 candidates out of which 20 are boys. The average marks obtained by boys is 12 with a variance 2. The variance of marks obtained by 30 girls is also 2. The average marks of all 50 candidates is 15. If μ is the average marks of girls and σ^2 is the variance of marks of 50 candidates, then $\mu + \sigma^2$ is equal to _____.

Response Type : Numeric

Evaluation Required For SA : Yes

Show Word Count : Yes

Answers Type : Equal

Text Areas : PlainText

Possible Answers :

1